



Oil Smart[®]

Electric Utility Systems

The See Water Oil Smart[®] system is the proven solution for electric utilities. Utility Oil Smart[®] systems allow water to be pumped from transformer oil containment areas and underground vaults without the risk of pumping oil.

Features

- EPA SPCC & IEEE 980 Compliant
- Complete Utility Packaged Pumping System
- UL Listed & CSA Certified

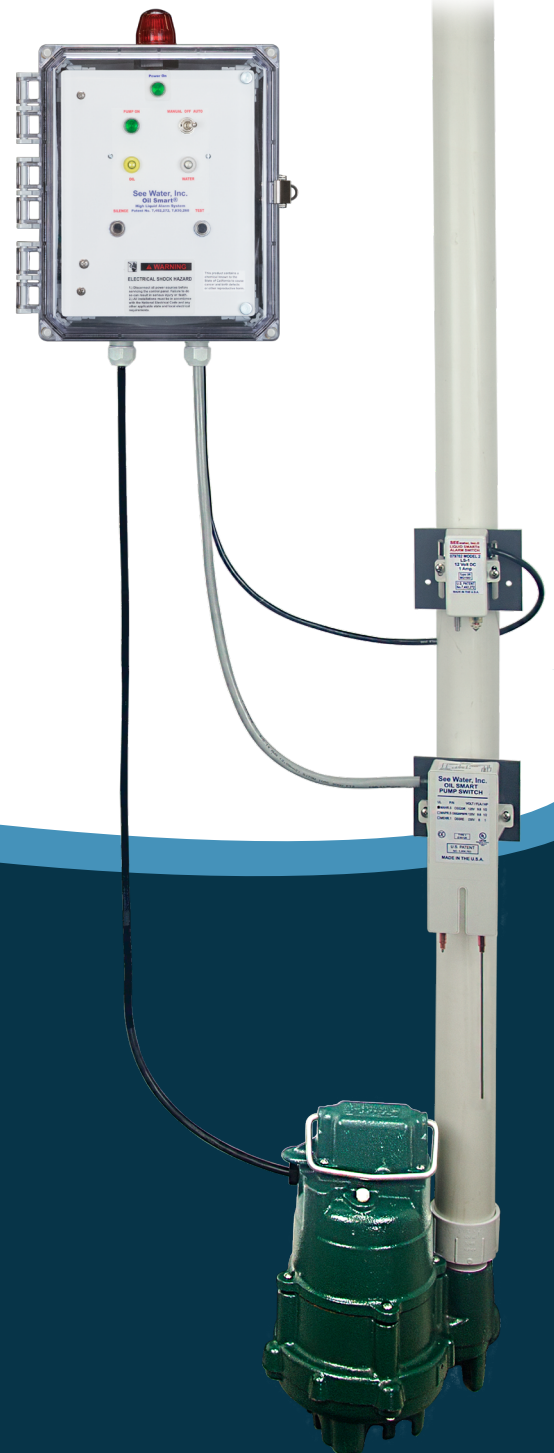

See Water's Oil Smart® electric utility kits are specifically designed for transformer containment vaults where there is a need to pump water without the risk of pumping hydrocarbons. Oil Smart® systems are the proven solution for the proper evacuation of water while complying with state and federal regulatory requirements (EPA SPCC and IEEE 980). The utility kits come complete with an Oil Smart® pump controller and fractional horsepower pump.

OSS20BPR6 Plug & Play Kit

- Directly controls sump pumps 0 to 1 hp
- Quick and easy installation
- No panel required
- Rated for 120VAC
- Standard 20' cord with pigtail connection



OSSIM-TP-1 Upgraded Simplex Kit

- Rated for 120/208/240VAC single phase
- Controls a single phase pump up to 28 FLA
- Outdoor/Indoor NEMA 4X enclosure
- Upgraded pump protection: Motor protective switch
- Remote monitoring dry contacts
- Includes Oil Smart® pump switch and Liquid Smart® alarm sensor



OSSIM-30 Simplex Kit

- Controls one 120/208/240VAC pump up to 16 FLA
- Outdoor/Indoor 10" x 8" x 4" NEMA 4X enclosure
- Alarm visual indicators
- Remote monitoring dry contacts
- Includes Oil Smart® pump switch and Liquid Smart® alarm sensor



OSD1P Duplex Kit

- Rated for 120/208/240VAC single phase
- Outdoor/Indoor NEMA 4X enclosure
- Controls two single phase pumps up to 28 FLA
- Two-pump alternation and high demand two-pump operation
- Upgraded pump protection: Motor protective switches included for both pumps



Pump Information

Pump Comparison Chart				
Model	HP	Amps	Volts-Phase	Type
151	1/3	6	115-1	Cast Iron
152	4/10	8.5	115-1	Cast Iron
153	1/2	10.5	115-1	Cast Iron

208, 240, 480VAC, Three-Phase Pump/Controls Available

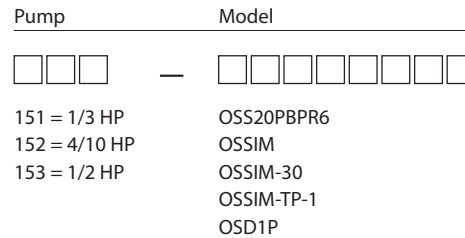

Pump Features

- Made of durable cast iron
- Automatic reset thermal overload protected
- Non-clogging vortex impeller
- Model 151 - 1/3 HP Passes 1/2" spherical solids
- Model 152 - .4 HP Passes 3/4" spherical solids
- Model 153 - 1/2 HP Passes 3/4" spherical solids
- CSA Certified C/US Tested to UL Standard CSA22.2 No. 108

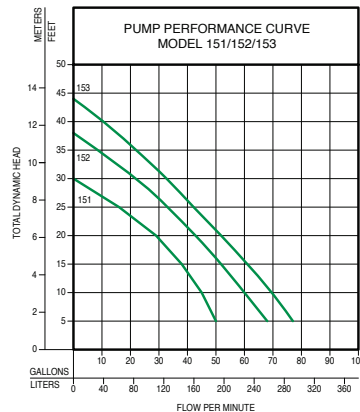

Model 151

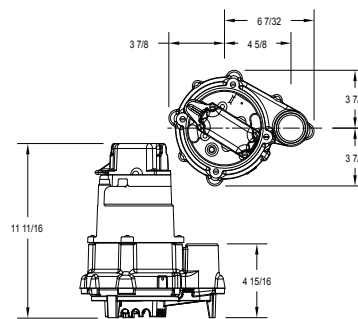

Model 152/153

